

# Plastic chain scraper

## With level skimmer type ŘSPS

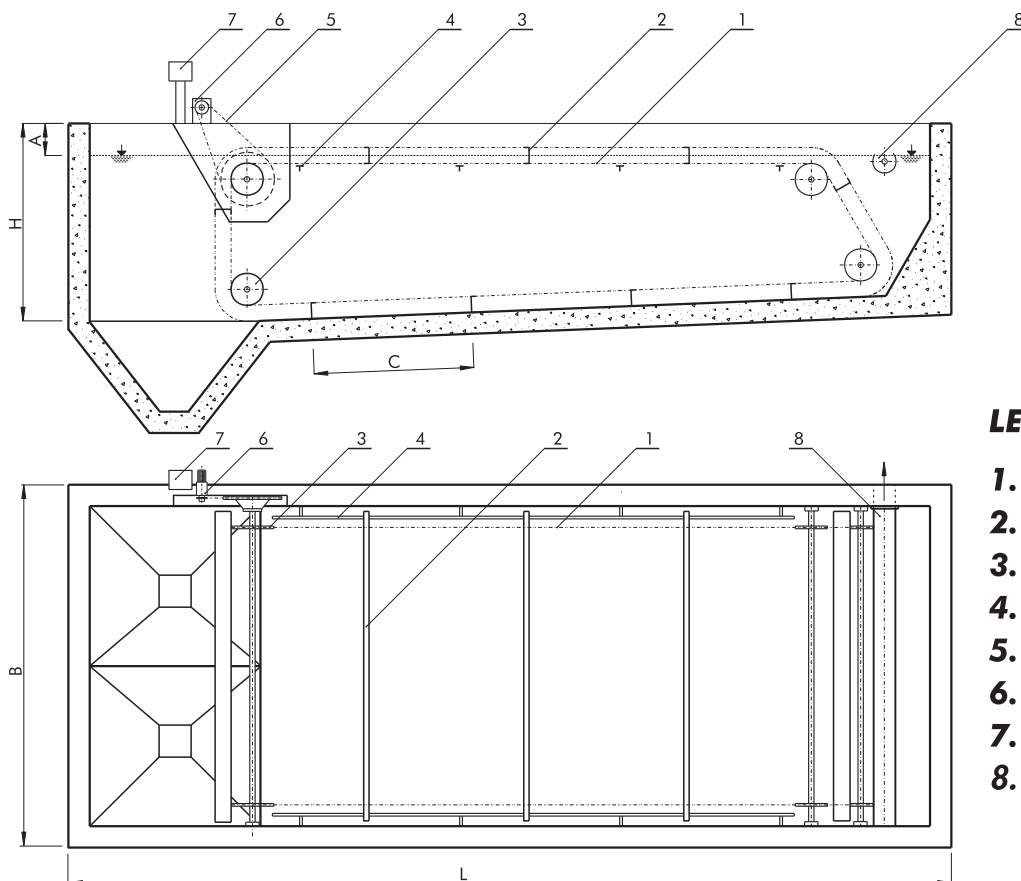

### LEGEND:

1. Chain
2. Scraper blades
3. Chain wheel shaft
4. Guide rail
5. Driving chain
6. Gear and electromotor
7. Pendant unit
8. Withdrawal of floating pollutants

TABLE OF MAIN DIMENSIONS:

Parameter	Designation	Size	Size	Modification
Tank width	B	m	3,0 through 6,0	0,3 m
Tank length	L	m	12,0 through 45,0	3,0 m
Tank depth	H	m	2,4 through 4,5	0,3 m
Distance of water level	A	m	0,6 through 1,2	0,2 m
Blade spacing	C	m	3,0	
Scraper velocity	v	m.s <sup>-1</sup>	0,016 through 0,040	according to used gearbox
Installed load	P	kW	0,25 through 1,1	in accordance with size

R.č. ŘSPS-K 02/08-C-en

## Plastic chain scraper

### With level skimmer type ŘSPS

#### APPLICATION

The chain scraper type ŘSPS with bottom and level scrapers is used to withdraw sediment sludge and floating pollutants from rectangular, lengthwise settling and final settling tanks. It is necessary to add the chain scraper amongst further equipment of the settling tank. Together with further equipment in settling tanks or as part of the final settling tank type Floc-In, it serves as clarification unit. The pretreatment for this treatment consists of coarse preliminary clarification by means of screens, gravel trap, sand trap, etc. The equipment is not dedicated to withdraw heavy industry sludge with a high amount of abrasive pollutions.

#### FUNCTIONAL PRINCIPLE

The chain scraper consists of two plastic plain coil chains and scraper blades. The chain scraper is always guided by two out of four chain wheels. The chain wheels are located on four shafts. The scraper blades are guided in horizontally as well as diagonal position by two guide rails. The chain scraper is driven by an external gearbox. The driving shaft is driven by a drive chain wheel which transmits the force on a pinion by means of a plastic driving chain. The chains are protected against overstressing and disruption by means of a shearing pin. The operation of the chain scraper can be controlled from the independent pendant unit or according to contract. Under minimal constructional changes, this chain scraper can be used for reconstruction of existing metal chain scrapers.

#### MATERIAL DESIGN

By default, the chain scraper is made of a combination of plastics (chains, chain wheels, guide rails) and construction steel (shafts). Metallization of the shafts or construction of chemically resistant steel is optionally possible.

#### OPERATION AND MAINTENANCE

The operation of the facility does not require constant care. Their maintenance however needs to be done in accordance with the instructions. In particular: The maintenance of the tightened chain and the operation of the equipment according to the rules (avoiding the scraper blades to be covered with sludge).

#### DELIVERY FORM

The equipment is the total scraper type ŘSPS including delivery and installation of additional equipment. The disposition of equipment (equal to the dimensions, which are listed in the table of the main dimensions) can be individually reviewed and is the subject of the technical explanation. The supplier reserves in compliance with the parameters of the equipment right for a change of deliveries contrary graphical illustrations.

#### DELIVERY DATE

According to contract